



RAM FROZEN FRY DISPENSER

RAM 280-F

FIRST IN FRY DISPENSING

Automated Fry Dispensing From a Freezer Cabinet

Fits Footprint of AFD-280
Series Fry Dispensers

Benefits:

Dispenses fries direct from freezer resulting in improved fry quality, consistency and yield

Dual dispensing system easily keeps pace with a 4-battery fryer

Cools to meet operational needs in approximately one hour

Ergonomic basket fill location

Electronic weighing system is extremely reliable

Certified local agent support available

Free technical phone support available 24/7

RAM 280-F



Only 28 inches / 72 centimeters wide
48 lbs. / 22 kg. Hopper Capacity
(Fry Baskets Sold Separately)



Shown with door removed

Automated Equipment LLC

5140 Moundview Dr.
Red Wing, MN 55066

info@autoequipllc.com

800-309-1053
651-385-2270



Automated Equipment LLC

5140 Moundview Dr.
Red Wing, MN 55066 USA

800-309-1053 US/Canada Sales
651-385-2270 International
651-385-2166 Fax

www.autoequipllc.com

RAM FROZEN FRY DISPENSER

SYSTEM OVERVIEW:

The RAM 280-F dispenses frozen fries on demand from a freezer cabinet. This ensures that the fries are cooked from frozen resulting in improved product quality, consistency and yield. The dual dispensing system enables the operator to fill two baskets simultaneously by sliding the baskets back into the fill position. An inductive basket sensor detects, then delivers a portion controlled load of fries into the baskets. Filled baskets are then removed and placed into the fryer for cooking.

Operation of the RAM 280-F Frozen Fry Dispenser is easily controlled by a power switch, dual portion control keys and a series of menu functions located on the operator control panel. The LED control display is used for calibration, system diagnostics and to signal a system error has occurred. The dual series of portion control keys (left-side and right-side) are used to select the desired basket load weight and will flash to indicate to the crew that the hopper is empty.

The RAM 280-F delivers the same dependable, efficient performance you've come to expect from the RAM line of fry dispensers. In addition, it is supported by our trained and certified local agents and our free technical phone support which is available 24/7.

SYSTEM SPECIFICATIONS:

HOPPER SIZE: dual hopper system holds 48 pounds / 22 kg

LENGTH: 28 inches / 72 cm

DEPTH: 30.5 inches / 78 cm

HEIGHT: 75 inches / 191 cm

WEIGHT: approximately 440 pounds / 220 kg

REQUIRED POWER: 120 VAC at 9 Amps, US/Canada

UL/cUL And NSF Listed

POWER CORD LENGTH: 8 feet / 2.43 meters

SYSTEM FEATURES:

- All components are electrically driven and controlled
- Dispenser stores eight baskets
- Fills baskets with 0.75 lb. / 0.35 kg, 1.0 lb. / 0.45 kg or 1.5 lb. / 0.7 kg of frozen fries
- Hopper fill height is 56.6 inches / 144 cm
- Inductive basket sensor is not triggered by non-metallic objects (senses only metal)
- Reversible cabinet door can be opened to left or right side
- Refrigeration filter is easy to remove and clean
- Disassembles for easy daily cleaning
- Hash brown rack and fry bucket standard equipment included with dispenser

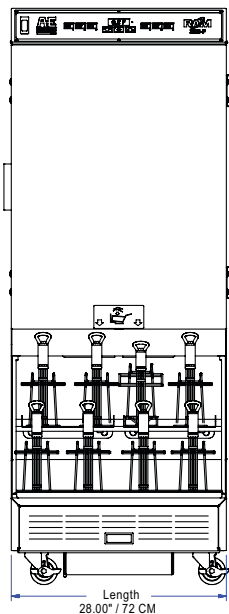

FRONT VIEW

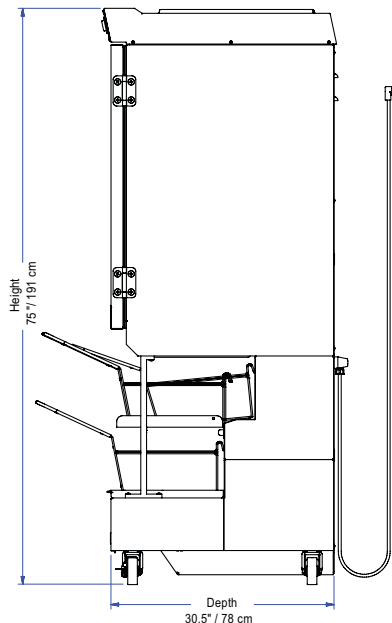

SIDE VIEW



Automated Equipment LLC

5140 Moundview Dr.
Red Wing, MN 55066 USA

800-309-1053 US/Canada Sales
651-385-2270 International
651-385-2166 Fax

www.autoequipllc.com

© 2007 Automated Equipment LLC
All rights Reserved - Published 02/07